

APPENDIX : 3D GEOMETRY

In our study of coordinate geometry we used coordinates to study planar geometry. We can easily extend the use of coordinates to study geometry in three dimensions; this is what we'll be doing in this chapter.

Most of the discussion of this chapter follows in a very straight forward manner from our discussions on Vectors; that is the reason for this topic being discussed in the Appendix. It is being assumed in the subsequent discussions that you have studied Vectors very thoroughly. You will, in due course, realise that the relations and formulae we derive in this chapter are nothing but slightly different expressions of things we've already covered in Vectors.

Section - 1

INTRODUCTION : BASIC FORMULAE

As we have studied in the chapter on vectors, we need three non-coplanar directions as our reference axis to specify the position of any point. It is most convenient to take the three non-coplanar directions (denoted conventionally by x , y and z directions) as being mutually perpendicular to each other.

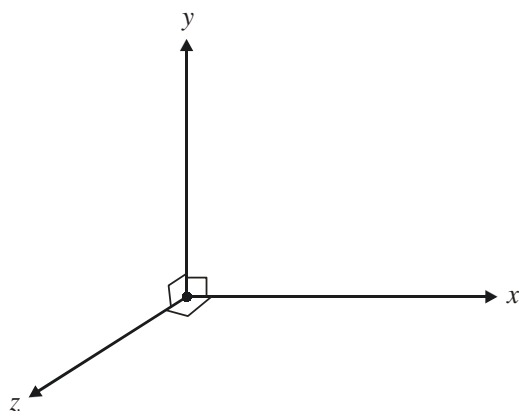

A rectangular axes in three dimensions. Note that the positive directions of the x -, y - and z -axis form a right handed system.

Fig - 1

Such a reference axes is termed a **rectangular coordinate** axis. Any point P in space can now be specified with respect to this frame by specifying the components (coordinates) of P along each axis.

For example, in the figure below,

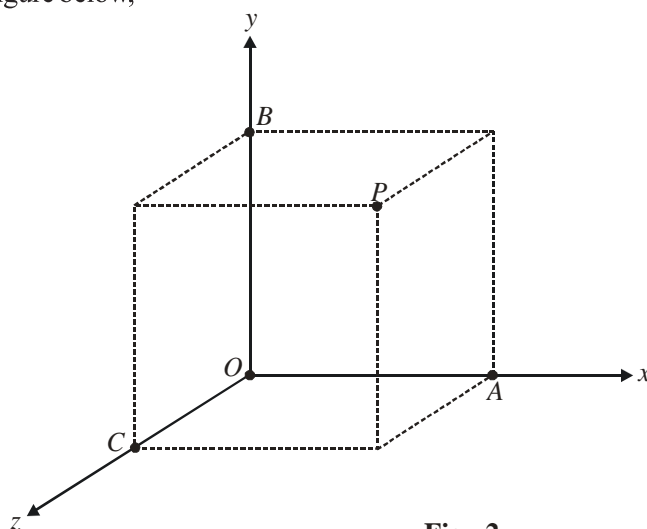

Assume
 $OA = a$
 $OB = b$
 $OC = c$

Fig - 2

the coordinates of P along the x -, y - and z -axis are given to be a , b and c . Thus, P can be specified as

$$P \equiv (a, b, c)$$

In two dimensions, two coordinates were sufficient to uniquely determine any point; in three dimensions, we need three coordinates.

Note that a two dimensional coordinate axes divides the plane into four quadrants; a three dimensional coordinate axes will divide the space into eight “compartments” known as **octants**. As an elementary exercise, write down the coordinates of some arbitrary points in each of the eight octants.

DISTANCE FORMULA

Let $A(x_1, y_1, z_1)$ and $B(x_2, y_2, z_2)$ be two arbitrary points. We need to find the distance between A and B in terms of the coordinates of A and B . Observe the following diagram carefully:

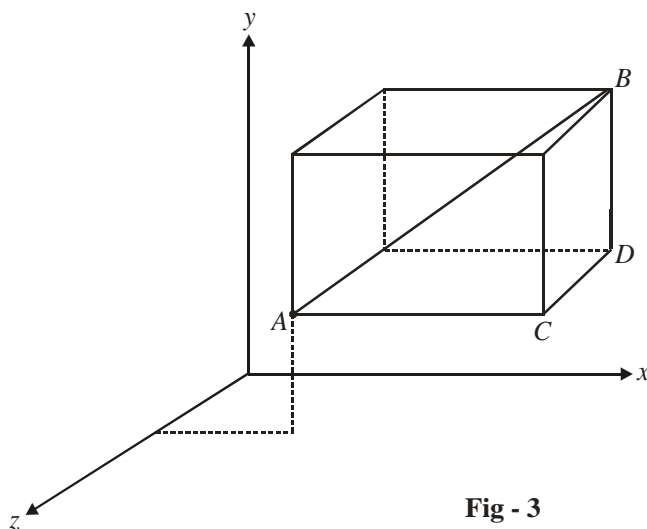

Fig - 3

Note that since

$$A \equiv (x_1, y_1, z_1)$$

$$B \equiv (x_2, y_2, z_2)$$

we have

$$AC = |x_2 - x_1|$$

$$CD = |y_2 - y_1|$$

$$BD = |z_2 - z_1|$$

AB is simply the length of the diagonal of the cuboid drawn (as depicted above):

$$AB^2 = AC^2 + CD^2 + BD^2$$

$$AB^2 = (x_1 - x_2)^2 + (y_1 - y_2)^2 + (z_1 - z_2)^2$$

$$\Rightarrow \boxed{AB = \sqrt{(x_1 - x_2)^2 + (y_1 - y_2)^2 + (z_1 - z_2)^2}}$$

This is the distance formula for three dimensions. It has a form exactly similar to the distance formula for two dimensions.

As an example, let $A \equiv (1, 2, 3)$, $B \equiv (3, 2, 1)$ and $C \equiv (2, 2, 2)$. We have,

$$AB = \sqrt{(1-3)^2 + (2-2)^2 + (3-1)^2} = 2\sqrt{2}$$

$$BC = \sqrt{(3-2)^2 + (2-2)^2 + (1-2)^2} = \sqrt{2}$$

$$AC = \sqrt{(1-2)^2 + (2-2)^2 + (3-2)^2} = \sqrt{2}$$

Incidentally, C is the mid point of AB since $AC + BC = AB$ and $AC = BC$.

Example – 1

Find the locus of the point P equidistant from the four points $O(0, 0, 0)$, $A(x, 0, 0)$, $B(0, y, 0)$ and $C(0, 0, z)$.

Solution: Let $P \equiv (a, b, c)$

We have,

$$\begin{aligned} OP^2 &= AP^2 \\ \Rightarrow a^2 + b^2 + c^2 &= (a-x)^2 + b^2 + c^2 \\ \Rightarrow a^2 &= (a-x)^2 \\ &= a^2 + x^2 - 2ax \\ \Rightarrow a &= \frac{x}{2} \end{aligned}$$

Similarly, $b = \frac{y}{2}$ and $c = \frac{z}{2}$. Thus, the point P is $\left(\frac{x}{2}, \frac{y}{2}, \frac{z}{2}\right)$. ◀

Example – 2

Find the locus of a point P which moves so that its distances from the points $A(0, 2, 3)$ and $B(2, -2, 1)$ are always equal.

Solution: P will obviously lie on the perpendicular bisector of AB . Let the co-ordinates of P be (x, y, z) . Therefore,

$$\begin{aligned} PA^2 &= PB^2 \\ \Rightarrow x^2 + (y-2)^2 + (z-3)^2 &= (x-2)^2 + (y+2)^2 + (z-1)^2 \\ \Rightarrow x - 2y - z + 1 &= 0 \end{aligned}$$

This is the required locus of P (if you think carefully, it is a plane) ◀

SECTION FORMULA

Consider two arbitrary points $A(x_1, y_1, z_1)$ and $B(x_2, y_2, z_2)$. We need to find the coordinates of the points P and Q dividing AB internally and externally respectively, in the ratio $m : n$.

The approach used in the evaluation of the coordinates of P and Q is analogous to how we derived the section formula in the two dimensional case.

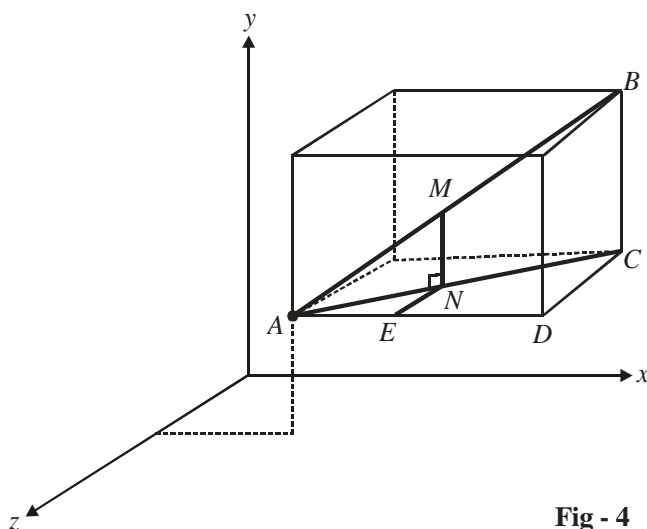

Let M be the point on AB such that

$$\frac{AM}{MB} = \frac{m}{n}$$

Drop a perpendicular (MN) from M onto AC .

Fig - 4

In $\triangle ABC$, we have

$$\frac{AM}{AB} = \frac{AN}{AC} = \frac{MN}{BC} \quad \dots(1)$$

Assume the coordinates of M to be (x, y, z) . Thus, the relation in (1) can be written as

$$\frac{m}{m+n} = \frac{AE}{AD} = \frac{MN}{BC} = \frac{NE}{CD} \quad \left(\because \text{ in } \triangle ACD, \frac{AN}{AC} = \frac{AE}{AD} = \frac{NE}{CD} \right)$$

$$\Rightarrow \frac{m}{m+n} = \frac{x-x_1}{x_2-x_1} = \frac{y-y_1}{y_2-y_1} = \frac{z-z_1}{z_2-z_1}$$

$$\Rightarrow x = \frac{mx_2 + nx_1}{m+n}, \quad y = \frac{my_2 + ny_1}{m+n}, \quad z = \frac{mz_2 + nz_1}{m+n}$$

Thus, the coordinates of M are

$$M \equiv \left(\frac{mx_2 + nx_1}{m+n}, \frac{my_2 + ny_1}{m+n}, \frac{mz_2 + nz_1}{m+n} \right)$$

The form of the coordinates is the same as in the two dimensional case, as might have been expected. The coordinates of M' which divides AB externally in the ratio $m : n$ can be obtained by substituting $-n$ for n in the coordinates of M .

As elementary applications of the section formula, do the following problems :

- (a) The mid-points of the sides of a triangle are $(1, 5, -1)$, $(0, 4, -2)$ and $(2, 3, 4)$. Find its vertices.
- (b) Find the coordinates of the centroid of the triangle with vertices $(x_i, y_i, z_i), i = 1, 2, 3$.

DIRECTION COSINES AND DIRECTION RATIOS

The direction cosines of a (directed) line are the cosines of the angles which the line makes with the positive directions of the coordinate axes.

Consider a line OL as shown, passing through the origin O . Let OL be inclined at angles α, β, γ to the coordinate axes.

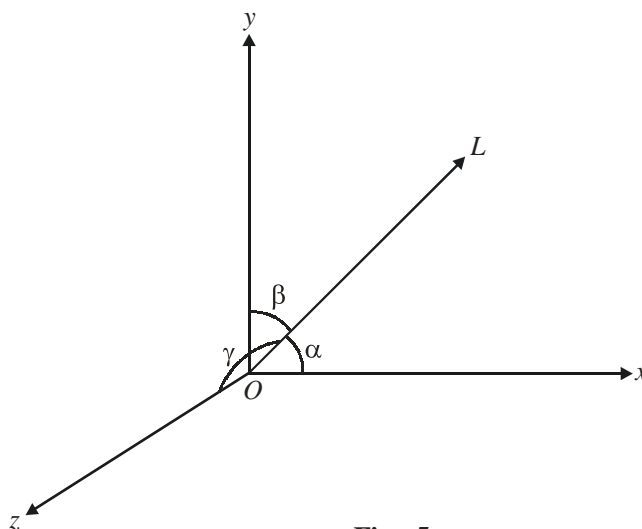

Fig - 5

Thus, the direction cosines are given by

$$l = \cos \alpha, \quad m = \cos \beta, \quad n = \cos \gamma$$

Note that for the line LO (i.e., the directed line segment in the direction opposite to OL), the direction cosines will be $-l, -m, -n$.

The direction cosines for a directed line L **not** passing through the origin are the same as the direction cosines of the directed line parallel to L and passing through the origin.

Note that for any point P lying on the line OL with direction cosines l, m, n such that $OP = r$, the coordinates of P will be

$$x = lr, \quad y = mr, \quad z = nr$$

$$\Rightarrow \quad p \equiv (lr, mr, nr)$$

Now, since

$$OP = r$$

$$\Rightarrow \sqrt{l^2 r^2 + m^2 r^2 + n^2 r^2} = r$$

$$\Rightarrow \boxed{l^2 + m^2 + n^2 = 1}$$

The direction cosines of **any** line will satisfy this relation.

The direction ratios are simply a set of three real numbers a, b, c proportional to l, m, n , i.e.

$$\frac{l}{a} = \frac{m}{b} = \frac{n}{c}$$

From this relation, we can write

$$\frac{a}{l} = \frac{b}{m} = \frac{c}{n} = \pm \frac{\sqrt{a^2 + b^2 + c^2}}{\sqrt{l^2 + m^2 + n^2}} = \sqrt{a^2 + b^2 + c^2}$$

$$\Rightarrow \boxed{l = \pm \frac{a}{\sqrt{a^2 + b^2 + c^2}}, m = \pm \frac{b}{\sqrt{a^2 + b^2 + c^2}}, n = \pm \frac{c}{\sqrt{a^2 + b^2 + c^2}}}$$

These relations tell us how to find the direction cosines from direction ratios.

Note that the direction cosines for any line must be unique. However, there are infinitely many sets of direction ratios since direction ratios are just a set of any three numbers proportional to the direction cosines.

Example – 3

How many lines can we draw that are equally inclined to each of the three coordinate axis?

Solution: Intuitively, we can expect the answer to be 8, one for each of the 8 octants. Lets try to derive this answer rigorously.

Assume the direction cosines of the lines to be l, m, n . Thus,

$$l^2 + m^2 + n^2 = 1 \quad \dots(1)$$

But since the lines are equally inclined to the three axes, we have $|l| = |m| = |n|$. This gives using (1),

$$|l| = |m| = |n| = \frac{1}{\sqrt{3}}$$

$$\Rightarrow l = \pm \frac{1}{\sqrt{3}}, m = \pm \frac{1}{\sqrt{3}}, n = \pm \frac{1}{\sqrt{3}}$$

It is obvious that 8 combinations of l, m, n are possible. Hence, 8 lines can be drawn which are equally inclined to the axes. 

Example – 4

Find the direction cosines of the line segment joining $A(x_1, y_1, z_1)$ and $B(x_2, y_2, z_2)$.

Solution: Refer to Fig - 4. Note that the x , y and z -components of the segment AB are AD , CB and DC respectively. If the direction cosines of AB are l, m, n and the length of AB is d , we have

$$ld = x_2 - x_1, \quad md = y_2 - y_1, \quad nd = z_2 - z_1$$

Thus, the direction cosines of AB are given by

$$l = \frac{x_2 - x_1}{d}, \quad m = \frac{y_2 - y_1}{d}, \quad n = \frac{z_2 - z_1}{d}$$

This result is quite important and will be used frequently in subsequent discussions. ◀

Example – 5

Find the projection of the line segment joining the points $A(x_1, y_1, z_1)$ and $B(x_2, y_2, z_2)$ onto a line with direction cosines l, m, n .

Solution: Let us first consider a vector approach to this problem. The vector \overline{AB} can be written as

$$\overline{AB} = (x_2 - x_1)\hat{i} + (y_2 - y_1)\hat{j} + (z_2 - z_1)\hat{k}$$

A unit vector \hat{u} along the line with direction cosines l, m, n will be

$$\hat{u} = l\hat{i} + m\hat{j} + n\hat{k}$$

Therefore, the projected length of \overline{AB} upon this line will be.

$$\begin{aligned} d &= |\overline{AB} \cdot \hat{u}| \\ &= |l(x_2 - x_1) + m(y_2 - y_1) + n(z_2 - z_1)| \end{aligned}$$

This assertion can also be proved without resorting to the use of vectors. For this, we first understand the projection of a sequence of line segments on a given line.

Assume $P_1, P_2, P_3, \dots, P_n$ to be n points in space. The sum of projections of the sequence of segments $P_1P_2, P_2P_3, \dots, P_{n-1}P_n$ onto a fixed line L will be the same as the projection of P_1P_n onto L . This should be obvious from the following diagram:

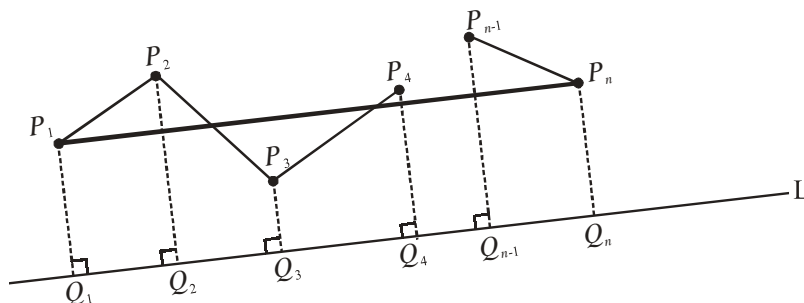

Fig - 6

The projection of the segment P_1P_n onto L is Q_1Q_n . The sum of projections of segments $P_1P_2, P_2P_3, \dots, P_{n-1}P_n$ onto L is $Q_1Q_2 + Q_2Q_3 + \dots + Q_{n-1}Q_n = Q_1Q_n$.

We use this fact in our original problem as follows:

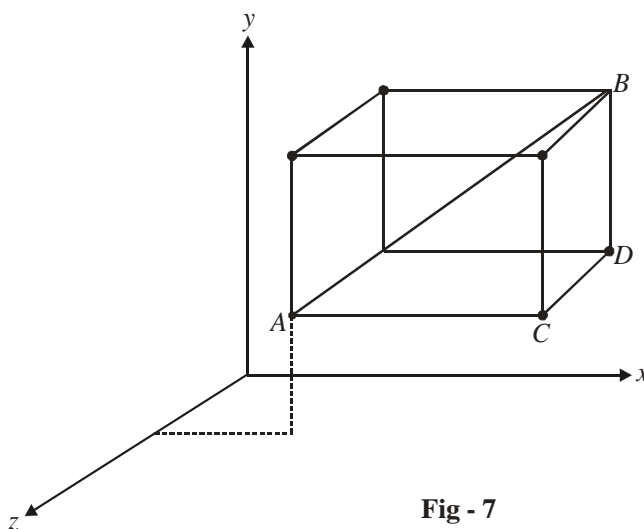

Fig - 7

The projection d of AB onto any line L (with direction cosines say l, m, n) will be sum of projections of AC, CD, DB onto L . Since $AC, CD,$ and DB are $l(x_2 - x_1), m(y_2 - y_1)$ and $n(z_2 - z_1)$ respectively, we get the total projection of AB onto L as

$$d = |l(x_2 - x_1) + m(y_2 - y_1) + n(z_2 - z_1)| \quad \blacktriangleleft$$

Example – 6

Two lines L_1 and L_2 have direction cosines $\{l_1, m_1, n_1\}$ and $\{l_2, m_2, n_2\}$ respectively. Find the angle at which L_1 and L_2 are inclined to each other respectively.

Solution: The unit vectors \hat{u}_1 and \hat{u}_2 along L_1 and L_2 respectively can be written as

$$\hat{u}_1 = l_1\hat{i} + m_1\hat{j} + n_1\hat{k}, \quad \hat{u}_2 = l_2\hat{i} + m_2\hat{j} + n_2\hat{k}$$

The angle θ between \hat{u}_1 and \hat{u}_2 (and hence L_1 and L_2) is given by

$$\cos\theta = \hat{u}_1 \cdot \hat{u}_2 = l_1l_2 + m_1m_2 + n_1n_2$$

$$\Rightarrow \theta = \cos^{-1}(l_1l_2 + m_1m_2 + n_1n_2)$$

We can deduce the following conditions on the direction cosines of L_1 and L_2 .

If L_1 and L_2 :
are parallel

$$\vec{u}_1 = \lambda\vec{u}_2$$

:

$$\Rightarrow \boxed{\frac{l_1}{l_2} = \frac{m_1}{m_2} = \frac{n_1}{n_2}}$$

If L_1 and L_2
are perpendicular:

$$\vec{u}_1 \cdot \vec{u}_2 = 0$$

$$\Rightarrow \boxed{l_1l_2 + m_1m_2 + n_1n_2 = 0}$$

What will be the corresponding conditions had a set of direction ratios been specified instead of the direction cosines? ◀

Example – 7

For the lines L_1 and L_2 of the previous example, find the direction cosines of the line L_3 perpendicular to both L_1 and L_2 .

Solution: Let the unit vector along L_3 be \vec{u}_3 . We have,

$$\vec{u}_3 = \vec{u}_1 \times \vec{u}_2$$

$$= \begin{vmatrix} \hat{i} & \hat{j} & \hat{k} \\ l_1 & m_1 & n_1 \\ l_2 & m_2 & n_2 \end{vmatrix}$$

$$= \hat{i}(m_1n_2 - m_2n_1) + \hat{j}(n_1l_2 - n_2l_1) + \hat{k}(l_1m_2 - l_2m_1)$$

Since \vec{u}_3 is a unit vector itself, the direction cosines of L_3 are simply

$$(m_1n_2 - m_2n_1), (n_1l_2 - n_2l_1), (l_1m_2 - l_2m_1) \quad \blacktriangleleft$$

Example – 8

Find the angle between the lines whose direction cosines are given by the equations

$$3l + m + 5n = 0, \quad 6mn - 2nl + 5lm = 0$$

Solution: Using the value of m from the first equation in the second, we have

$$-6(3l + 5n)n - 2nl - 5l(3l + 5n) = 0$$

$$\Rightarrow 45ln + 30n^2 + 15l^2 = 0$$

$$\Rightarrow 2n^2 + 3ln + l^2 = 0$$

$$\Rightarrow (2n + l)(n + l) = 0$$

$$\Rightarrow 2n = -l \quad \text{or} \quad n = -l$$

For $l = -2n$, we obtain $m = n$. A set of direction ratios of one line is therefore $\{-2n, n, n\}$.

For $l = -n$, we obtain $m = -2n$. A set of direction ratios of the other line is therefore $\{-n, -2n, n\}$.

Using the result of example 6 (the one that you were asked to prove at the end of the question), the angle between the two lines can now be evaluated to be $\cos^{-1}\left(\frac{1}{6}\right)$. ◀

Section - 2**PLANE**

In the chapter on Vectors, we have already learnt how to write the equations for a plane, in different forms. In this section, we will extend that discussion and learn how to write the equation of a plane in three dimensional coordinates form.

The general vector equation of a plane is of the form

$$\vec{r} \cdot \vec{n} = l \quad ; \quad l \text{ is a constant}$$

where \vec{r} is the variable vector $x\hat{i} + y\hat{j} + z\hat{k}$ representing any point on the plane, while \vec{n} is a fixed vector, say $a\hat{i} + b\hat{j} + c\hat{k}$ which is perpendicular to the plane. Thus, the equation of the plane can be written as

$$(x\hat{i} + y\hat{j} + z\hat{k}) \cdot (a\hat{i} + b\hat{j} + c\hat{k}) = l$$

$$\Rightarrow ax + by + cz = l$$

$$\Rightarrow \boxed{ax + by + cz + d = 0} \quad ; d = -l$$

This is the most general equation of a plane in coordinate form. Note that this equation of the plane contains only three arbitrary constants, for, it can be written as

$$\left(\frac{a}{d}\right)x + \left(\frac{b}{d}\right)y + \left(\frac{c}{d}\right)z + 1 = 0$$

$$\Rightarrow \lambda_1 x + \lambda_2 y + \lambda_3 z + 1 = 0$$

Thus, three independent constraints are sufficient to uniquely determine a plane. For example, three non collinear points are sufficient to uniquely determine the plane passing through them.

Example – 9

Write the equation of an arbitrary plane passing through the point $A(x_1, y_1, z_1)$.

Solution Let us denote the position vector of A by \vec{A} ; \vec{A} is therefore $x_1\hat{i} + y_1\hat{j} + z_1\hat{k}$. Now, assume that the normal to the plane is $\vec{n} = a\hat{i} + b\hat{j} + c\hat{k}$, where a, b, c are variable :

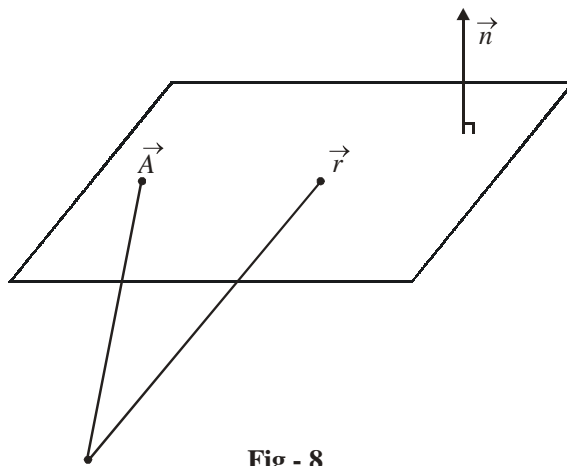

Fig - 8

Thus, for any variable point $\vec{r} = x\hat{i} + y\hat{j} + z\hat{k}$ on the plane, since $(\vec{r} - \vec{A})$ is perpendicular to \vec{n} , we have

$$(\vec{r} - \vec{A}) \cdot \vec{n} = 0$$

$$\Rightarrow ((x - x_1)\hat{i} + (y - y_1)\hat{j} + (z - z_1)\hat{k}) \cdot (a\hat{i} + b\hat{j} + c\hat{k}) = 0$$

$$\Rightarrow a(x - x_1) + b(y - y_1) + c(z - z_1) = 0 \quad \dots(1)$$

This is the required equation of an arbitrary plane through the point $A(x_1, y_1, z_1)$.

We could have arrived at this equation alternatively as follows: we assume the general equation of a plane which is

$$ax + by + cz + d = 0 \quad \dots(2)$$

If this passes through (x_1, y_1, z_1) we have

$$ax_1 + by_1 + cz_1 + d = 0 \quad \dots(3)$$

By (2)–(3), we arrive at the same equation as in (1). ◀

Example – 10

Find the equation of the plane passing through the points $P(1, 1, 0)$, $Q(1, 2, 1)$ and $R(-2, 2, -1)$.

Solution: Let $S(x, y, z)$ be any arbitrary point in the plane whose equation we wish to determine:

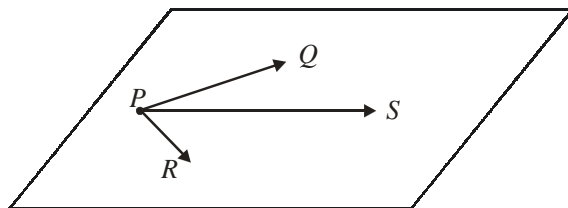

Fig - 9

Since $\overline{PQ} \times \overline{PR}$ will be perpendicular to this plane, we must have

$$\overline{PS} \cdot (\overline{PQ} \times \overline{PR}) = 0$$

$$\begin{aligned} \Rightarrow & \left\{ (x-1)\hat{i} + (y-1)\hat{j} + z\hat{k} \right\} \cdot \begin{vmatrix} \hat{i} & \hat{j} & \hat{k} \\ 0 & 1 & 1 \\ -3 & 1 & -1 \end{vmatrix} = 0 \\ \Rightarrow & \left\{ (x-1)\hat{i} + (y-1)\hat{j} + z\hat{k} \right\} \cdot (-2\hat{i} - 3\hat{j} + 3\hat{k}) = 0 \\ \Rightarrow & 2(x-1) + 3(y-1) - 3z = 0 \\ \Rightarrow & 2x + 3y - 3z = 5 \end{aligned}$$

We could have proceeded alternatively as follows: using the result of the last example, any arbitrary plane through $P(1, 1, 0)$ will be of the form

$$\begin{aligned} & a(x-1) + b(y-1) + cz = 0 \\ \Rightarrow & \lambda_1(x-1) + \lambda_2(y-1) + z = 0 \quad ; \lambda_1 = \frac{a}{c}, \lambda_2 = \frac{b}{c} \end{aligned}$$

If this passes through $Q(1, 2, 1)$ and $R(-2, 2, -1)$, we have

$$\lambda_2 + 1 = 0$$

and
$$-3\lambda_1 + \lambda_2 - 1 = 0$$

$$\Rightarrow \lambda_1 = -\frac{2}{3}, \lambda_2 = -1$$

Thus, the equation of the plane is

$$-\frac{2}{3}(x-1) - (y-1) + z = 0$$

$$\Rightarrow 2(x-1) + 3(y-1) - 3z = 0$$

$$\Rightarrow 2x + 3y - 3z = 5$$

Example – 11

Find the equation of the plane intercepting lengths a, b and c on the x -, y - and z -axis respectively.

Solution: The plane passes through the points $A(a, 0, 0)$, $B(0, b, 0)$ and $C(0, 0, c)$. For any variable point $S(x, y, z)$ in this plane, we have (as discussed in the previous section),

$$\overline{AS} \cdot (\overline{AB} \times \overline{AC}) = 0$$

$$\Rightarrow \{(x-a)\hat{i} + y\hat{j} + z\hat{k}\} \cdot \begin{vmatrix} \hat{i} & \hat{j} & \hat{k} \\ -a & b & 0 \\ -a & 0 & c \end{vmatrix} = 0$$

$$\Rightarrow \{(x-a)\hat{i} + y\hat{j} + z\hat{k}\} \cdot (bc\hat{i} + ac\hat{j} + ab\hat{k}) = 0$$

$$\Rightarrow (bc)(x-a) + acy + abz = 0$$

$$\Rightarrow bcx + acy + abz = abc$$

$$\Rightarrow \boxed{\frac{x}{a} + \frac{y}{b} + \frac{z}{c} = 1}$$

This general equation has the same form as the equation of the line in intercept form; which further proves the analogy between the formulae in two and in three dimensions.

Example – 12

A plane is at a distance p from the origin and the direction cosines of the (outward) normal to it are l, m, n . Find its equation.

Solution: The unit vector \hat{n} normal to the plane is

$$\hat{n} = l\hat{i} + m\hat{j} + n\hat{k}$$

For any point $\vec{r} (x\hat{i} + y\hat{j} + z\hat{k})$ in the plane, we have

$$\vec{r} \cdot \hat{n} = p$$

$$\Rightarrow lx + my + nz = p$$

This is the required equation; it is called the normal form of the plane's equation. As an exercise, convert the general equation of the plane

$$ax + by + cz + d = 0$$

into normal form. 

Example – 13

Find the angle of intersection of the two planes

$$a_1x + b_1y + c_1z + d_1 = 0$$

$$a_2x + b_2y + c_2z + d_2 = 0$$

Solution: From the equations of the planes, it is evident that the following vectors are to these planes respectively:

$$\vec{n}_1 = a_1\hat{i} + b_1\hat{j} + c_1\hat{k}$$

$$\vec{n}_2 = a_2\hat{i} + b_2\hat{j} + c_2\hat{k}$$

Since the acute angle θ between the two planes will be the acute angle between their normals, we have

$$\begin{aligned} \cos \theta &= \frac{|\vec{n}_1 \cdot \vec{n}_2|}{|\vec{n}_1| |\vec{n}_2|} \\ &= \frac{|a_1a_2 + b_1b_2 + c_1c_2|}{\sqrt{a_1^2 + b_1^2 + c_1^2} \sqrt{a_2^2 + b_2^2 + c_2^2}} \end{aligned}$$

Incidentally, we can now derive the conditions for these planes to be parallel or perpendicular.

$$\text{Planes are parallel if } \vec{n}_1 = \lambda \vec{n}_2 \quad \Rightarrow \quad \frac{a_1}{a_2} = \frac{b_1}{b_2} = \frac{c_1}{c_2}$$

$$\text{Planes are perpendicular if } \vec{n}_1 \times \vec{n}_2 = 0 \quad \Rightarrow \quad a_1 a_2 + b_1 b_2 + c_1 c_2 = 0$$

It should be obvious that for two parallel planes, their equations can be written so that they differ only in the constant term. Thus, any plane parallel to $ax + by + cz + d = 0$ can be written as $ax + by + cz + d' = 0$ where $d' \in \mathbb{R}$ (and $d' \neq d$). ◀

Example – 14

- (a) Find the distance of the point $P(x_1, y_1, z_1)$ from the plane $ax + by + cz + d = 0$.
- (b) Find the distance between the two parallel planes

$$ax + by + cz + d_1 = 0$$

$$ax + by + cz + d_2 = 0$$

Solution: (a) The distance l of P from the given plane will obviously be measured along the normal to the plane passing through P :

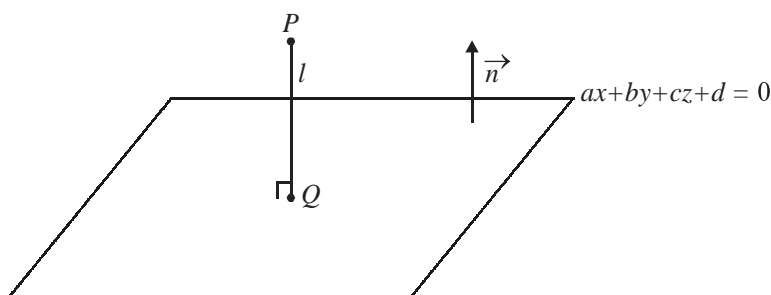

Fig - 10

We write the equation of the plane as

$$\vec{r} \cdot \vec{n} = -d$$

where $\vec{r} = x\hat{i} + y\hat{j} + z\hat{k}$ is any point on the plane and $\vec{n} = a\hat{i} + b\hat{j} + c\hat{k}$ is the normal to the plane.

Let O be the origin. Since Q lies on the plane, its position vector \overline{OQ} must satisfy the equation of the plane. But $\overline{OQ} = \overline{OP} + \overline{PQ}$. Thus,

$$(\overline{OP} + \overline{PQ}) \cdot \vec{n} = -d$$

Note that $\overline{PQ} = \frac{\lambda \vec{n}}{|\vec{n}|}$ where $\lambda = \pm l$ (which sign to take depends on which direction \vec{n} points in).

Thus,

$$\begin{aligned} & \left(\overline{OP} + \frac{\lambda \vec{n}}{|\vec{n}|} \right) \cdot \vec{n} = -d \\ \Rightarrow & \overline{OP} \cdot \vec{n} + \frac{\lambda \vec{n} \cdot \vec{n}}{|\vec{n}|} = -d \\ \Rightarrow & (x_1 \hat{i} + y_1 \hat{j} + z_1 \hat{k}) \cdot (a \hat{i} + b \hat{j} + c \hat{k}) + \lambda |\vec{n}| = -d \\ \Rightarrow & ax_1 + by_1 + cz_1 + d = -\lambda |\vec{n}| \\ \Rightarrow & |\lambda| = l = \frac{|ax_1 + by_1 + cz_1 + d|}{|\vec{n}|} \\ \Rightarrow & l = \frac{|ax_1 + by_1 + cz_1 + d|}{\sqrt{a^2 + b^2 + c^2}} \end{aligned}$$

(b) Assume any point $P(x_1, y_1, z_1)$ on the first plane. We have

$$\begin{aligned} & ax_1 + by_1 + cz_1 + d_1 = 0 \\ \Rightarrow & d_1 = -(ax_1 + by_1 + cz_1) \quad \dots(1) \end{aligned}$$

The distance of P from the second plane, say l , can be evaluated as described in part (a) above :

$$l = \frac{|ax_1 + by_1 + cz_1 + d_2|}{\sqrt{a^2 + b^2 + c^2}} \quad \dots(2)$$

Using (1) in (2), we have

$$l = \frac{|d_2 - d_1|}{\sqrt{a^2 + b^2 + c^2}}$$

This is the required distance between the two planes. 

Example – 15

Find the equation of the plane (s) bisecting the angle(s) between two given planes

$$P_1 \equiv a_1x + b_1y + c_1z + d_1 = 0$$

$$P_2 \equiv a_2x + b_2y + c_2z + d_2 = 0$$

Solution: Note that as in the case of the intersection of straight lines, there will be two (supplementary) angles formed when two planes intersect: one will be acute and the other obtuse (or both could be right). The angle bisector plane of two planes has essentially the same property as the angle bisector of two lines: any point on the angle bisector plane of the planes P_1 and P_2 will be equidistant from P_1 and P_2 .

If we assume an arbitrary point $S(x, y, z)$ on the angle bisector plane(s) of P_1 and P_2 , we have,

$$\begin{aligned} \text{Distance of } S \text{ from } P_1 &= \text{Distance of } S \text{ from } P_2 \\ \Rightarrow \frac{|a_1x + b_1y + c_1z + d_1|}{\sqrt{a_1^2 + b_1^2 + c_1^2}} &= \frac{|a_2x + b_2y + c_2z + d_2|}{\sqrt{a_2^2 + b_2^2 + c_2^2}} \\ \Rightarrow \frac{a_1x + b_1y + c_1z + d_1}{\sqrt{a_1^2 + b_1^2 + c_1^2}} &= \pm \frac{a_2x + b_2y + c_2z + d_2}{\sqrt{a_2^2 + b_2^2 + c_2^2}} \end{aligned}$$

As expected, we get two angle bisector planes, one corresponding to the “+” and one to the “-” sign.

As in the case of straight line angle bisectors, we can prove that the equation of the angle bisector containing the origin will be given by the “+” sign if d_1 and d_2 are of the same sign. You are urged to prove this as an exercise.

For two planes with equations

$$P_1 \equiv a_1x + b_1y + c_1z + d_1 = 0 \quad \equiv \quad \vec{r} \cdot \vec{n}_1 + d_1 = 0$$

$$P_2 \equiv a_2x + b_2y + c_2z + d_2 = 0 \quad \equiv \quad \vec{r} \cdot \vec{n}_2 + d_2 = 0$$

we have already proved in the chapter on vectors that **any** plane passing through the intersection line of P_1 and P_2 can be written as

$$P_1 + \lambda P_2 = 0, \quad \lambda \in \mathbb{R}$$

Let us use this to solve a problem. ◀

Example – 16

Find the equation of the plane passing through the line of intersection of

$$P_1 \equiv x + 3y - 6 = 0$$

$$P_2 \equiv 3x - y + 4z = 0$$

and at a unit distance from the origin.

Solution: Any plane through the intersection line of P_1 and P_2 can be written as

$$\begin{aligned} P_1 + \lambda P_2 &= 0 \\ \Rightarrow (1 + 3\lambda)x + (3 - \lambda)y + 4\lambda z - 6 &= 0 \quad \dots(1) \end{aligned}$$

The distance of this plane from the origin $(0, 0, 0)$ is 1. We thus have, using the formula for the distance of a point from a plane,

$$\frac{|(1+3\lambda)0 + (3-\lambda)0 + 4\lambda(0) - 6|}{\sqrt{(1+3\lambda)^2 + (3-\lambda)^2 + (4\lambda)^2}} = 1$$

$$\Rightarrow (1+3\lambda)^2 + (3-\lambda)^2 + (4\lambda)^2 = 36$$

$$\Rightarrow \lambda = \pm 1$$

Thus, in fact two such planes will exist. Using the values of λ obtained in (1), the equations of these two planes will be $2x + y + 2z + 3 = 0$ and $-x + 2y - 2z + 3 = 0$. ◀

Section - 3

STRAIGHT LINE

In this section, we'll discuss how to write the equation for a straight line in coordinate form. There are essentially two different ways of doing so:

UNSYMMETRICAL FORM OF THE EQUATION OF A LINE: A line can be defined as the intersection of two planes. Thus, the equations of two planes considered together represents a straight line. For example, the set of equations

$$a_1x + b_1y + c_1z + d_1 = 0$$

$$a_2x + b_2y + c_2z + d_2 = 0$$

represents the straight line formed by the intersection of these two planes. Recall that the planes will intersect only if they are non-parallel, i.e., only if

$$a_1 : b_1 : c_1 \neq a_2 : b_2 : c_2$$

SYMMETRICAL FORM OF THE EQUATION OF A LINE : Consider a line with direction cosines l, m, n and passing through the point $A(x_1, y_1, z_1)$. For any point $P(x, y, z)$ on this line, the set of numbers $\{(x - x_1), (y - y_1), (z - z_1)\}$ must be proportional to the direction cosines, as has already been discussed. Thus, the equation of this line can be written as

$$\frac{x - x_1}{l} = \frac{y - y_1}{m} = \frac{z - z_1}{n}$$

Extending this, we can write the equation of the line passing through $A(x_1, y_1, z_1)$ and $B(x_2, y_2, z_2)$ as

$$\frac{x - x_1}{x_2 - x_1} = \frac{y - y_1}{y_2 - y_1} = \frac{z - z_1}{z_2 - z_1}$$

Note that for any point $P(x, y, z)$ at a distance r from $A(x_1, y_1, z_1)$ along the line with direction cosines l, m, n , we have

$$\frac{x - x_1}{l} = \frac{y - y_1}{m} = \frac{z - z_1}{n} = r$$

Thus, the coordinates of P can be written as

$$x = x_1 + lr, \quad y = y_1 + mr, \quad z = z_1 + nr$$

This is a useful fact and we'll be using it frequently.

Example – 17

Find the direction cosines of the line $6x - 2 = 3y + 1 = 2z - 2$.

Solution: We have ,

$$6\left(x - \frac{1}{3}\right) = 3\left(y + \frac{1}{3}\right) = 2(z - 1)$$

$$\Rightarrow \frac{x - \frac{1}{3}}{1} = \frac{y + \frac{1}{3}}{2} = \frac{z - 1}{3}$$

Comparing this with the symmetrical form of the equation of a line, we can say that the direction ratios of this line are proportional to 1, 2, 3. Thus, the direction cosines are

$$l = \frac{1}{\sqrt{1^2 + 2^2 + 3^2}} = \frac{1}{\sqrt{14}}, \quad m = \frac{2}{\sqrt{14}}, \quad n = \frac{3}{\sqrt{14}}$$

$$\Rightarrow \text{The direction cosines are } \frac{1}{\sqrt{14}}, \frac{2}{\sqrt{14}}, \frac{3}{\sqrt{14}}.$$

Example – 18

Find the distance of the point $A(1, -2, 3)$ from the plane $x - y + z = 5$ measured parallel to the line $\frac{x}{2} = \frac{y}{3} = \frac{z}{-6}$.

Solution: The direction cosines of the line parallel to whom we wish to measure the distance, can be evaluated to be

$$\frac{2}{7}, \frac{3}{7}, -\frac{6}{7}$$

Thus, any point on the line through A with these direction cosines, at a distance r from A , will have the coordinates

$$\left(1 + \frac{2r}{7}, -2 + \frac{3r}{7}, 3 - \frac{6r}{7}\right)$$

If this point lies on the given plane, we have

$$\left(1 + \frac{2r}{7}\right) - \left(-2 + \frac{3r}{7}\right) + \left(3 - \frac{6r}{7}\right) = 5$$

$$\Rightarrow r = 1$$

Thus, the required distance is 1 unit. 

Example – 19

Find a set of direction ratios of the line

$$a_1x + b_1y + c_1z + d_1 = 0 ; a_2x + b_2y + c_2z + d_2 = 0$$

$$a_1 : b_1 : c_1 \neq a_2 : b_2 : c_2$$

Solution: The equation of the line has been specified in unsymmetric form, i.e., as the intersection of two non-parallel planes.

Visualise in your mind that when two planes intersect, the line of intersection will be perpendicular to normals to both the planes. Normal vectors to the two planes can be taken to be

$$\vec{n}_1 = a_1\hat{i} + b_1\hat{j} + c_1\hat{k}$$

$$\vec{n}_2 = a_2\hat{i} + b_2\hat{j} + c_2\hat{k}$$

Thus, the line of intersection will be parallel to $\vec{n}_1 \times \vec{n}_2$, i.e. to

$$\begin{vmatrix} \hat{i} & \hat{j} & \hat{k} \\ a_1 & b_1 & c_1 \\ a_2 & b_2 & c_2 \end{vmatrix} = \hat{i}(b_1c_2 - b_2c_1) + \hat{j}(c_1a_2 - a_1c_2) + \hat{k}(a_1b_2 - a_2b_1)$$

A set of direction ratios of the line of intersection can be taken to be

$$(b_1c_2 - b_2c_1), (c_1a_2 - a_1c_2), (a_1b_2 - a_2b_1) \quad \blacktriangleleft$$

Example – 20

Find the equation of the plane passing through the line

$$2x + y - z - 3 = 0 = 5x - 3y + 4z + 9$$

and parallel to the line $\frac{x-1}{2} = \frac{y-3}{4} = \frac{z-5}{5}$

Solution: In terms of a parameter λ , the equation of the plane that we require can be written as

$$(2x + y - z - 3) + \lambda(5x - 3y + 4z + 9) = 0$$

$$\Rightarrow (2 + 5\lambda)x + (1 - 3\lambda)y + (4\lambda - 1)z + (9\lambda - 3) = 0 \quad \dots(1)$$

For this plane to be parallel to the given line, its normal must be perpendicular to the given line. Using the condition for perpendicularity, we thus have

$$2(2 + 5\lambda) + 4(1 - 3\lambda) + 5(4\lambda - 1) = 0$$

$$\Rightarrow 3 + 18\lambda = 0$$

$$\Rightarrow \lambda = -\frac{1}{6}$$

Using this value of λ in (1), we get the required equation of the plane as $7x + 9y - 10z = 27$. ◀

ASSIGNMENT (3-D GEOMETRY)

Q. 1 Show that the points $A(3, 3, 3)$, $B(0, 6, 3)$, $C(1, 7, 7)$ and $D(4, 4, 7)$ are the vertices of a square.

Q. 2 Show that the plane $ax + by + cz + d = 0$ divides the line joining the points (x_1, y_1, z_1) and (x_2, y_2, z_2) in the ratio $-\frac{ax_1 + by_1 + cz_1 + d}{ax_2 + by_2 + cz_2 + d}$.

Q. 3 A directed line segment makes angles 45° and 60° with x -axis and y -axis respectively and an acute angle with z -axis. If $P(-1, 2, -3)$ and $Q(4, 3, 1)$ are two points in space, find the projection of PQ on the given line.

Q. 4 If the edges of a rectangular parallelepiped are a, b, c , prove that the angles between the four diagonals are given by

$$\cos^{-1} \left(\frac{a^2 \pm b^2 \pm c^2}{a^2 + b^2 + c^2} \right)$$

Q. 5 Find the angle between the lines whose direction cosines are connected by the relations:

$$l - 5m + 3n = 0 \quad \text{and} \quad 7l^2 + 5m^2 - 3n^2 = 0$$

Q. 6 Show that the straight lines whose direction cosines are given by the equations $al + bm + cn = 0$ and $ul^2 + vm^2 + wn^2 = 0$ are perpendicular, if $a^2(v + w) + b^2(u + w) + c^2(u + v) = 0$ and, parallel, if $\frac{a^2}{u} + \frac{b^2}{v} + \frac{c^2}{w} = 0$.

Q. 7 Show that the four points $(0, -1, -1)$, $(-4, 4, 4)$, $(4, 5, 1)$ and $(3, 9, 4)$ are coplanar. Find the equation of the plane containing them.

Q. 8 Find the equation of the plane that bisects the segment joining the points $(1, 2, 3)$ and $(3, 4, 5)$ at right angles.

Q. 9 Prove that the points $A(x_1, y_1, z_1)$ and $B(x_2, y_2, z_2)$ lie on the same or opposite sides of the plane $ax + by + cz + d = 0$ accordingly as the expressions $(ax_1 + by_1 + cz_1 + d)$ and $(ax_2 + by_2 + cz_2 + d)$ are of the same or opposite signs.

Q. 10 A variable plane is at a constant distance p from the origin and meets the coordinate axes in A, B, C . Show that the locus of the centroid of the tetrahedron $OABC$ is $x^{-2} + y^{-2} + z^{-2} = 16p^{-2}$.

Q. 11 Show that the origin lies in the acute angle between the planes $x + 2y + 2z = 9$ and $4x - 3y + 12z + 13 = 0$.

- Q. 12** Let $P(x_1, y_1, z_1), Q(x_2, y_2, z_2)$ and $R(x_3, y_3, z_3)$ be the vertices of ΔPQR with area A . Let $\Delta P_1Q_1R_1, \Delta P_2Q_2R_2$ and $\Delta P_3Q_3R_3$ be the projections of ΔPQR on $y-z, z-x$ and $x-y$ planes respectively, and let their areas be A_x, A_y and A_z respectively. Prove that

$$A^2 = A_x^2 + A_y^2 + A_z^2$$

Generalize this result, if possible.

- Q. 13** P is a point on the plane $lx + my + nz = p$. A point Q is taken on the line OP such that $OP \cdot OQ = p^2$; prove that the locus of Q is $p(lx + my + nz) = x^2 + y^2 + z^2$

- Q. 14** Find the equation of two planes through the origin which are parallel to the line $\frac{x-1}{2} = \frac{y+3}{-1} = \frac{z+1}{-2}$ and at a distance of $\frac{5}{3}$ units from it.

- Q. 15** Show that the two lines

$$\frac{x-x_i}{l_i} = \frac{y-y_i}{m_i} = \frac{z-z_i}{n_i}, \quad i=1,2$$

are coplanar if

$$\begin{vmatrix} x_2 - x_1 & y_2 - y_1 & z_2 - z_1 \\ l_1 & m_1 & n_1 \\ l_2 & m_2 & n_2 \end{vmatrix} = 0$$

- Q. 16** Show that the lines $\frac{x+1}{-3} = \frac{y-3}{2} = \frac{z+2}{1}$ and $\frac{x}{1} = \frac{y-7}{-3} = \frac{z+7}{2}$ intersect. Find the coordinates of the point of intersection and the equation of the plane containing them.

- Q. 17** (i) Find the equation of the plane passing through the points $(2, 1, 0), (5, 0, 1)$ and $(4, 1, 1)$.
(ii) If P is the point $(2, 1, 6)$, then find the point Q such that PQ is perpendicular to the plane in (i) and the mid-point of PQ lies on it.

- Q. 18** Find the projection of the line $\frac{x-1}{3} = \frac{y-2}{4} = \frac{z-3}{5}$ on the plane $x - y + z + 2 = 0$.

- Q. 19** Find the locus of a point which moves in such a way that its distance from the line $\frac{x}{1} = \frac{y}{1} = \frac{z}{-1}$ is twice its distance from the plane $x + y + z = 0$.

- Q. 20** Prove that the lines $\frac{x-9}{2} = \frac{y+4}{-1} = \frac{z-5}{1}$ and $6x + 4y - 5z - 4 = 0 = x - 5y + 2z - 12$ are coplanar. Find also their point of intersection.

ANSWERS

ASSIGNMENT

Ans. 3 $\frac{5}{2}(\sqrt{2}+1)$

Ans. 7 $5x-7y+11z+4=0$

Ans. 8 $x+y+z=9$

Ans. 16 $(2,1,-3) ; x+y+z=0$

Ans. 17 $x+y-2z-3=0; (6,5,-2)$

Ans. 18 $\frac{x+2}{5} = \frac{y+2}{16} = \frac{z+2}{11}$

Ans. 19 $x^2 + y^2 + z^2 = 5xy + 3yz + 3zx$

Ans. 20 $(3,-1,2)$